



COOKTOP

Please see the following operational guidelines to ensure optimal usage of the Cooktop:

Date: June 2024

USING YOUR COOKTOP

To start cooking

- Turn the control dial of the cooking zone you wish to use to the High setting, then adjust as necessary.
- When using dual cooking zones, you may choose to use the inner zone only (⊙) or the full dual cooking zone (⊕).
- Some models have a cooking zone with a unique SuperSimmer feature. This special, low turndown range is excellent for the most delicate cooking tasks, like melting chocolate or simmering soups and stews.
- For further advice on cooking and using the SuperSimmer feature, see 'Cooking guidelines' following.

'Hot surface' indicators

- As soon as you turn a cooking zone on, its 'Hot surface' indicator will start glowing.
- It will continue to glow even after you have turned the cooking zone off, until the glass becomes cool enough to be safely touched.

When you have finished cooking

- When you have finished using a cooking zone, turn its dial to the off (O) position.
- When you have finished using your cooktop, check that all dials are turned off.

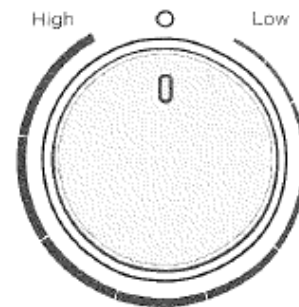

Single cooking zone control

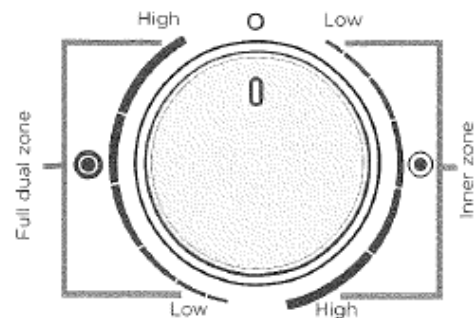

Dual cooking zone control
(some models only)

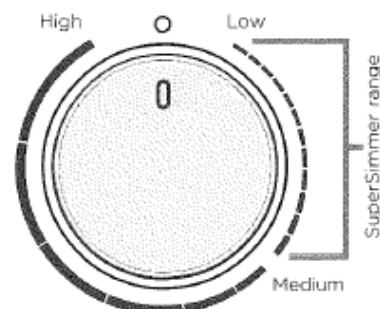

Cooking zone with SuperSimmer
(some models only)